

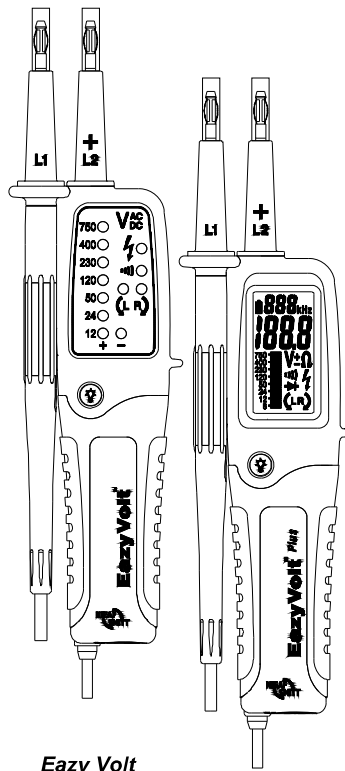

***Eazy Volt /Eazy Volt Plus***  
***Voltage Tester***  
***Instruction Manual***



***Eazy Volt***

***Eazy Volt Plus***

<b>TABLE OF CONTENTS</b>	<b>Page</b>
1. Safety	2
2. Symbols and Features	3
3. AC/DC V Measurements	4
4. Continuity / Diode Tests	5
5. Resistance Measurements	7
6. Single-Pole Phase Tests	7
7. Phase Rotation Tests	8
8. RCD Voltage Tests	10
9. Illumination	11
10. Frequency Tests	12
11. Auto Test	12
12. Battery Replacement	13
13. 4mm Tips Replacement	13
14. Cleaning	14
15. Transport And Storage	14
16. Maintenance	14
17. Specification	15
18. Warranty	17

## **1. Safety**

### **⚠ Safety Information**







To ensure safe operation and service of the Tester, follow these instructions.

Failure to observe warnings can result in severe **injury** or **death**.

- Avoid working alone so assistance can be rendered. If the operators safety can not be guaranteed, the Tester must be removed from service and protected against use.
- Prior to usage ensure perfect instrument function (e.g. on known voltage source) before and after the test.
- Do not connect the instrument to voltages higher than 750V.
- Do not open the battery cover before take off from voltage source.
- **The safety can no longer be insured if the Tester :**
  - shows obvious damage
  - does not carry out the desired measurements
  - has been stored for too long under unfavorable conditions
  - has been subjected to mechanical stress (i.e. during transport).
- All relevant statutory safety regulations must be adhered to when using this instrument.
- The Tester may no longer be used if one or several functions fail or if no functionality is indicated or the Tester looks damaged.
- When using this Tester, only the handles of the probes may be touched do not touch the probe tips (metal part).
- Do not use the Tester if the Tester is not operating properly or if it is wet.
- Use the Tester only as specified in the Instruction card including environmental conditions and the usage in dry environments must be followed or the protection by the Tester might be impaired.
- Use extreme caution when working around bare conductors or bus bar. Contact with the conductor could result in an electric shock.
- Use caution with voltages above 50V AC rms or 120V DC. These voltages pose a shock hazard.

## 2. Symbols and Features

### Symbols as marked on the Tester and Instruction manual

	Risk of electric shock
	See instruction manual
+ or -	+ DC or –DC measurement
	Equipment protected by double or reinforced insulation
	Battery
	Earth
±	AC measurement
	Conforms to EU directives
	High Voltage Detection

### List of features

- AC Voltage
- DC Voltage
- Continuity
- Resistance (Eazy Volt Plus)
- Single pole phase test
- Phase rotation of a three-phase mains
- Frequency test (Eazy Volt Plus)
- Auto test
- Probe tip torch
- Drop proof 1 meter
- IP 65 Protection
- Auto Power On/Off
- Selectable measuringpoints 2-4 mm
- Diode test

### 3. AC/DC V Measurements

#### AC V

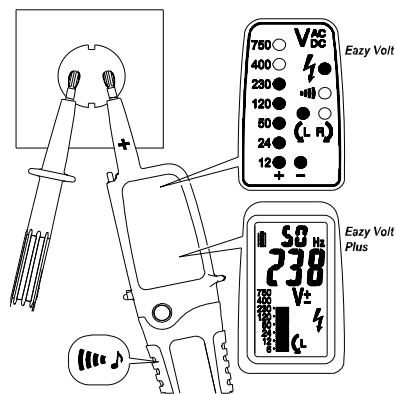

#### DC V

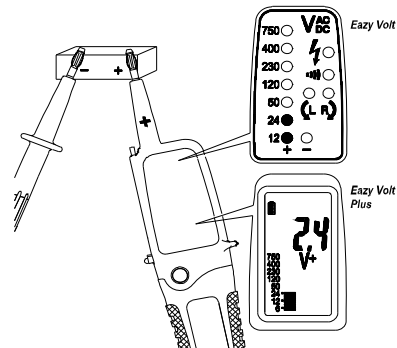

**Eazy Volt** : The safety LED can report a dangerous voltage > 50 V AC and 120 V DC

**Eazy Volt Plus** : The safety indicator can report a dangerous voltage > 50 V AC and 120 V DC.

⚠ If the tester is used in a noisy background, you need to ensure that the sound level of the tester is perceptible here.

## 4. Continuity / Diode Test

### Continuity Tests

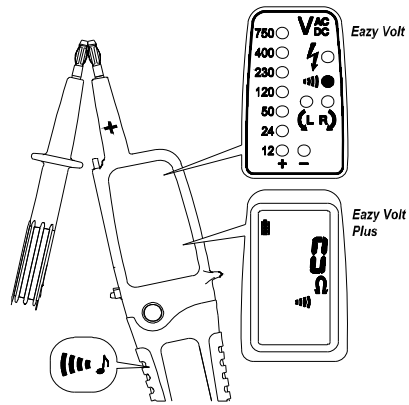

### Diode Tests

#### – Eazy Volt

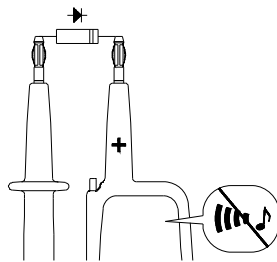
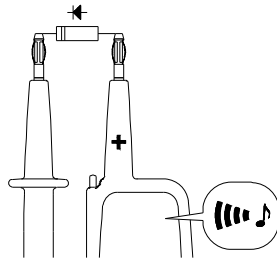

– Eazy Volt Plus

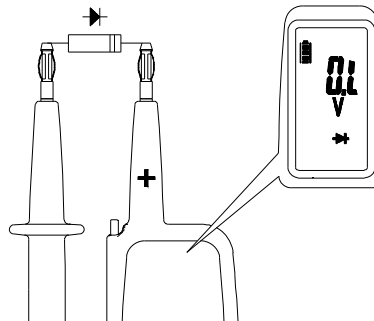
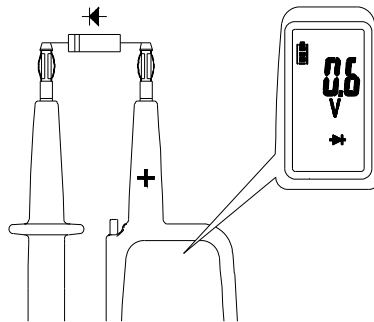

**⚠** The Continuity /  $\rightarrow$  test is only possible when batteries are installed and in good condition.

## 5. Resistance Measurements

$\Omega$  Only on Eazy Volt

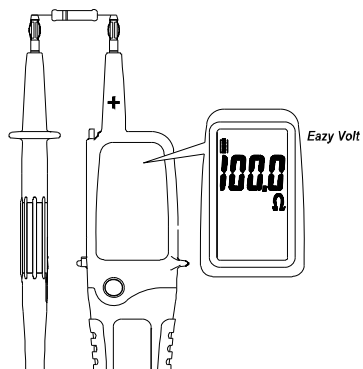

**⚠** The Resistance test is only possible when batteries are installed and in good condition.

## 6. Single-Pole Phase Test

*Single-Pole Phase*

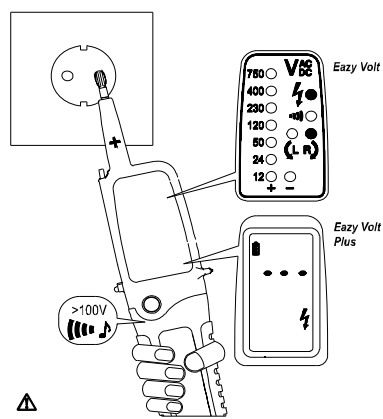



⚠ The single-pole phase test is only possible when batteries are installed and in good condition.

⚠ The single-pole phase test is not always appropriate for testing whether a circuit is not live. For this purpose, the bipolar test is required.

⚠ To determine external conductors during phase tests the display function may be impaired (e.g. for insulating body protection or insulating sites).

⚠ Firmly grasp the insulated grips of the Tester probe L2 it is better for increase the sensitivity of single-pole phase test.

## 7. Phase Rotation Test

### Rotary phase of a three-phase mains

- Right rotary field

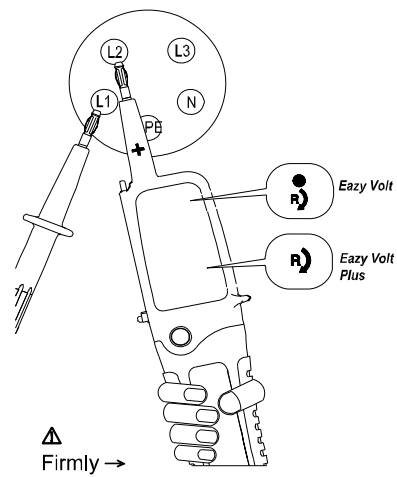

• Left rotary field

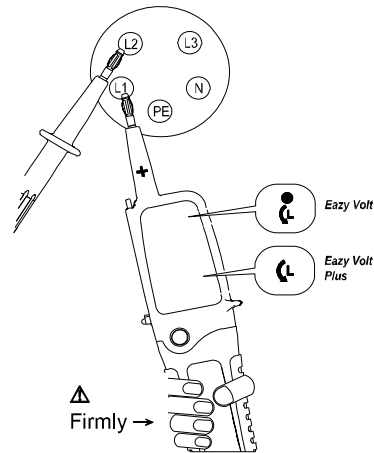

**⚠** Testing of phase-sequence direction is possible from 100V AC voltage (phase to phase) provided the neutral is earthed.

On making contact with both test electrodes (probe tips) to two phases of the three-phase power supply which are connected in clockwise rotation, a “C” symbol appears in the LCD Display.

If the rotation is anticlockwise, then a “C” symbol is displayed. In this case both phases of the unit should be switched around.

**⚠ Note :**

Testing the phase rotation always requires a negative phase rotation test!

To ensure a connect test, it is better to test on a known source.

**⚠ Attention :**

Please ensure that the test electrodes (probe tips) make good contact with two phases of a three-phase mains while testing the phase rotation. For absolute determination of a clockwise phase rotation it is necessary to make a negative phase rotation test after changing the phases. The indication “↻” or “↺” can be affected by unfavorable light conditions, by protective clothing or in insulated locations.

⚠ Firmly grasp the insulated grip of the Tester probe L2, it is better for the sensitivity of the phase rotation test.

## 8. RCD Voltage Test

### Voltage Test with RCD Trip Test

During voltage tests in systems equipped with RCD circuit breakers, a RCD switch can be tripped at a nominal residual current of 10mA or 30mA by measuring the voltage between L and PE.

These Testers are equipped with an internal load enabling the tripping of an RCD protection device of 10mA or 30mA.

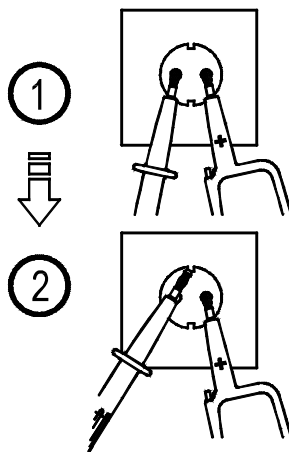

To avoid RCD tripping, a test has to be carried out between L and N during approx. 5sec. Immediately afterwards, voltage testing between L and PE can be carried out without RCD tripping.

## **9. Illumination**

### **Probe tip torch**

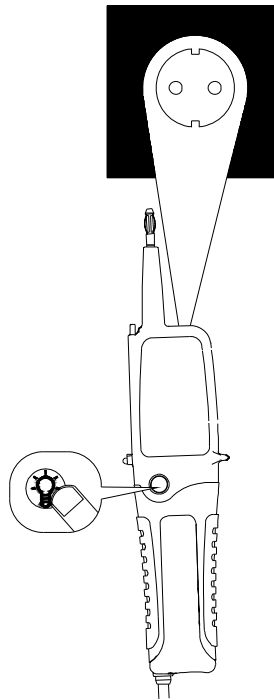

## 10. Frequency Tests

Only on Eazy Volt plus

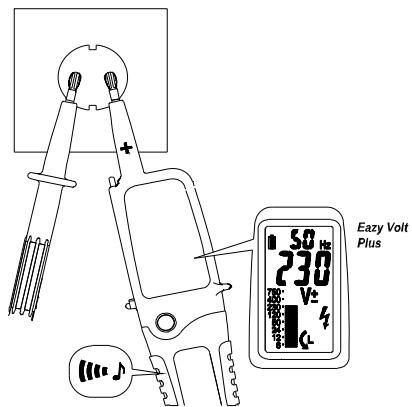

## 11. Auto Tests

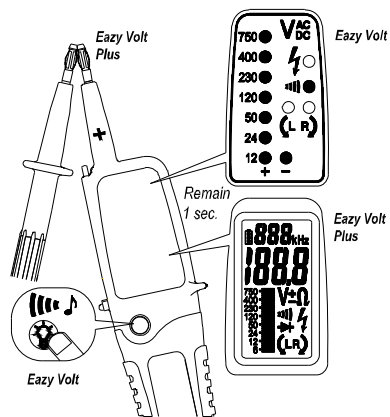

Eazy Volt :  
auto-test by pressing the yellow button

Eazy Volt Plus :  
auto-test by shorting the probes

⚠ If the instrument shows failure, please  
don't use it and send it to our service depart-  
ment for repair.

## 12. Battery Replacement

If no signal sound is audible (Eazy Volt) when short circuiting the test probes, if the symbol "⚡" is displayed (Eazy Volt Plus)

- Completely disconnect from the measurement circuit.
- Unscrew the screw by a cross screw driver, then open the battery cover.
- Remove discharged batteries.
- Replace by new batteries, type 1.5V IEC LR03 by respecting correct polarity.
- Close the battery cover and re-screw the screw.

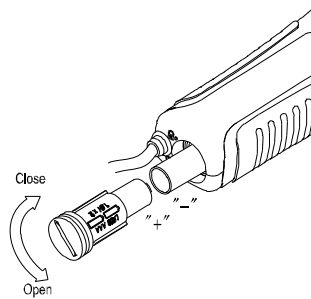

## 13. 4mm Tips Replacement

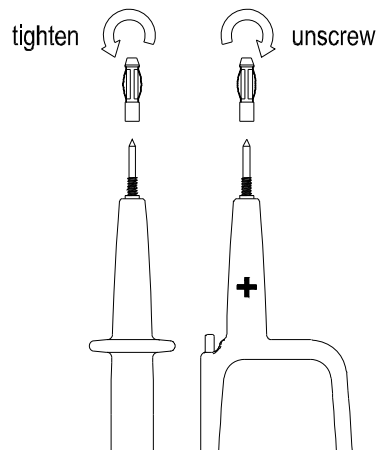

## **14. Cleaning**

Prior to cleaning, remove the instruments from all measurement circuits.

If the instruments are dirty after daily usage, it is advisable to clean them by using a damp cloth and a mild household detergent. Never use acid detergents or dissolvent for cleaning. After cleaning, do not use the voltage tester till it is dried completely.

## **15. Transport and Storage**

**⚠** In order to avoid instrument damage, it is advised to remove batteries when not using the instrument over a longer period.

The tester must be stored in dry and closed areas. In the case of an instrument being transported in extreme temperatures, a recovery time of minimum 2 hours is required prior to instrument operation.

## **16. Maintenance**

Unauthorized persons shall not disassemble the tester and the supplementary equipment.

When using testers in compliance with the instruction manual, no particular maintenance is required.

If functional errors occur during normal operating, our service department will check your instrument without delay.

## 17. Specification

The Instruments	Eazy Volt	Eazy Volt Plus
Voltage range	12...750V AC/DC	
LED/Bargraph resolution	± 12,24,50,120,230,400, 750V	
LCD voltage range	12V...750V AC/DC	
LCD resolution	1V	
Accuracy	AC ±(1.3%+5d) DC ±(1.0%+2d)	
Voltage detection	Automatic	
Acoustic signal sound	AC 50V DC 120V	
Polarity detection	Full range	
Range detection	Automatic	
Response time	<0.1s	<0.1s/BAR <2s/RDG
Frequency range	DC, 45...65Hz	
Automatic load (RCD)	Yes	
Peak current	Is <0.2A / Is(5s) <3.5mA	
Operation time	ED (DT)=30s.	
Recovery Time	10 min.	
Auto Power On	<12 VAC / DC	
<b>Single-pole Phase Test</b>		
Voltage range	100...750V AC	
Frequency range	45...65Hz	
<b>Resistance Test</b>		
Resistance Range	0...2KΩ	
Accuracy	±(2%+10d)	
Resolution	1Ω	
<b>Frequency Test</b>		
Frequency range	30Hz~999Hz	
Accuracy	±(0.3%+5d)	
Resolution	1Hz	
Vmax (61Hz~999Hz)	20VAC	



The Instruments	Eazy Volt	Eazy Volt Plus
<b>Continuity Test</b>		
Threshold	< 200K $\Omega$	< 200 $\Omega$
Diode Test		0.1~1.8V
Resolution		0.1V
Overvoltage protection	1000V AC/DC	
<b>Rotary Field Indication</b>		
Voltage range (LEDs)	100...750V	
Frequency range	50...60Hz	
Measurement principle	Double-pole and firmly hold the grip (L2)	
Power supply	2 x 1.5V IEC LR03 AAA size	
Power consumption	Max. 32mA / approx. 94m $\Omega$	
Operating Temperature	-15°C ~ 45°C	
Storage Temperature	-20°C ~ 60°C	
Temperature Coefficient	0.2x(Spec.Accuracy/°C <18°C >28°C)	
Humidity	Max. 85% relative humidity	
Height above sea level	Up to 2000m	
Pollution Degree	2	
Type of protection	IP65	
CE	EN61326 : EN55011 :	
Safety	EN61010-1 : 2010 EN61010-031 : 2008 EN61243-3 : 2010 UTE 18-510 EN60529 : 2000/AI2000	
Functionality	EN61243-3 : 2010 EN61557-7 : 2007 EN61557-10 : 2001 EN 61557-1 : 2007	
Weight	230g (VTB), 240g (VTS), (incl. Batteries)	
Dimensions	239x68x29mm	

<b>Overvoltage category</b>	
Overvoltage class	CAT III 1000V/ CAT IV 600V
CAT.	Application field
CAT I	The circuits not connected to mains.
CAT II	The circuits directly connected to Low-voltage Installation.
CAT III	The building installation
CAT IV	The source of the Low – voltage installation.

## **18. Warranty**

The Instruments are subject to strict quality control. However, should the instrument function improperly during normal use, you are protected by our two years warranty.

We will repair or replace free of charge any defects in workmanship material, provided the instrument is returned unopened and unhampered with.

Damage due to dropping or incorrect handling is not covered by the warranty.

If the instrument shows failure following expiry of warranty, our service department can offer you a quick and economical repair.



**Mors Smitt B.V.**

Vrieslantlaan 6  
3526 AA Utrecht

Postbus 7023  
3502 KA Utrecht  
The Netherlands

T +31 (0)30 288 13 11  
F +31 (0)30 289 88 16  
E [sales@nieaf-smitt.nl](mailto:sales@nieaf-smitt.nl)  
I [www.nieaf-smitt.nl](http://www.nieaf-smitt.nl)